

THIS DRAWING IS UNPUBLISHED. RELEASED FOR PUBLICATION  
 © COPYRIGHT BY TYCO ELECTRONICS CORPORATION. ALL RIGHTS RESERVED.

LOC	DIST	REVISIONS					
AF	50	P	LTR	DESCRIPTION	DATE	DWN	APVD
			C1	REVISED PER ECR-06-018443	09AUG06	MF	DD

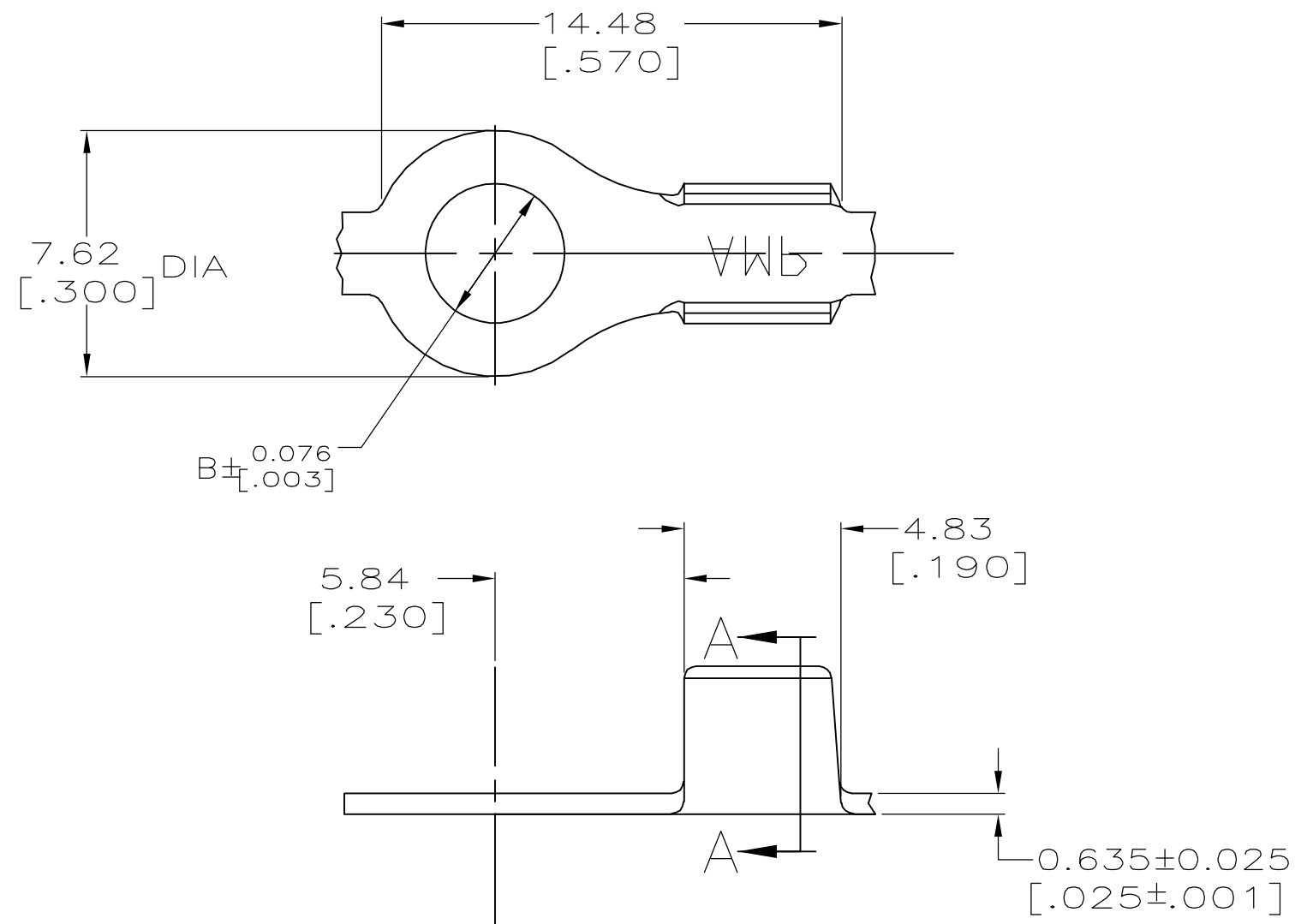

- 1 CONTINUOUS STRIP ON REELS.
- 2 0.00203 [0.000080] MIN TIN PLATE.
- 3 WIRE RANGE: 0.8-2.0mm<sup>2</sup> [18-14] AWG.
- 4 PACKAGED WITH INTERLEAVING PAPER.
- 5 PRELIMINARY - NOT FOR PRODUCTION.

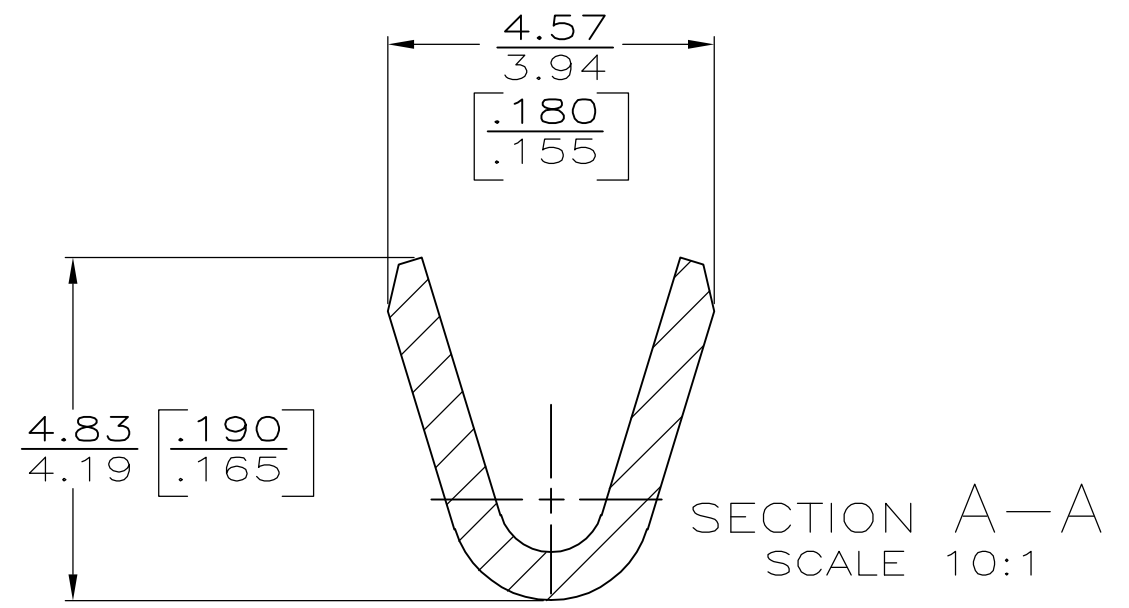

4	.171	5	42111-4
	.197		42111-3
	.171		42111-2
	.145		42111-1
	B DIMENSION		PART NUMBER

F	3.56 [0.140]	2.21 [0.087]	2.0mm <sup>2</sup> [14]
		2.03 [0.080]	1.3mm <sup>2</sup> [16]
		1.93 [0.076]	0.8mm <sup>2</sup> [18]
TYPE	WIDTH	±0.051 [±0.002] HEIGHT	WIRE
WIRE BARREL CRIMP			

THIS DRAWING IS A CONTROLLED DOCUMENT.		DWN 9AUG2006 MICHAEL S. FEHER
DIMENSIONS: mm [INCHES]		CHK 09AUG2006 DONALD F. DECKER
TOLERANCES UNLESS OTHERWISE SPECIFIED:		APVD 09AUG2006 DONALD F. DECKER
0 PLC ± -		PRODUCT SPEC -
1 PLC ± -		APPLICATION SPEC -
2 PLC ± -		WEIGHT -
3 PLC ± 0.38 [0.015]		CUSTOMER DRAWING
4 PLC ± -		SCALE 5:1
ANGLES ± -		SHEET 1 OF 1
FINISH - 2		REV C1
MATERIAL #1 HARD BRASS		

Tyco Electronics Corporation Harrisburg, PA 17105-3608		RING	
SIZE	CAGE CODE	DRAWING NO	RESTRICTED TO
A3	00779	C-42111	-